



HANDBUCH ENTNAHMEINHEIT MIT SAUGSONDE

DE - Handbuch

FR - Manuel

ES - Manual

EN - Manual



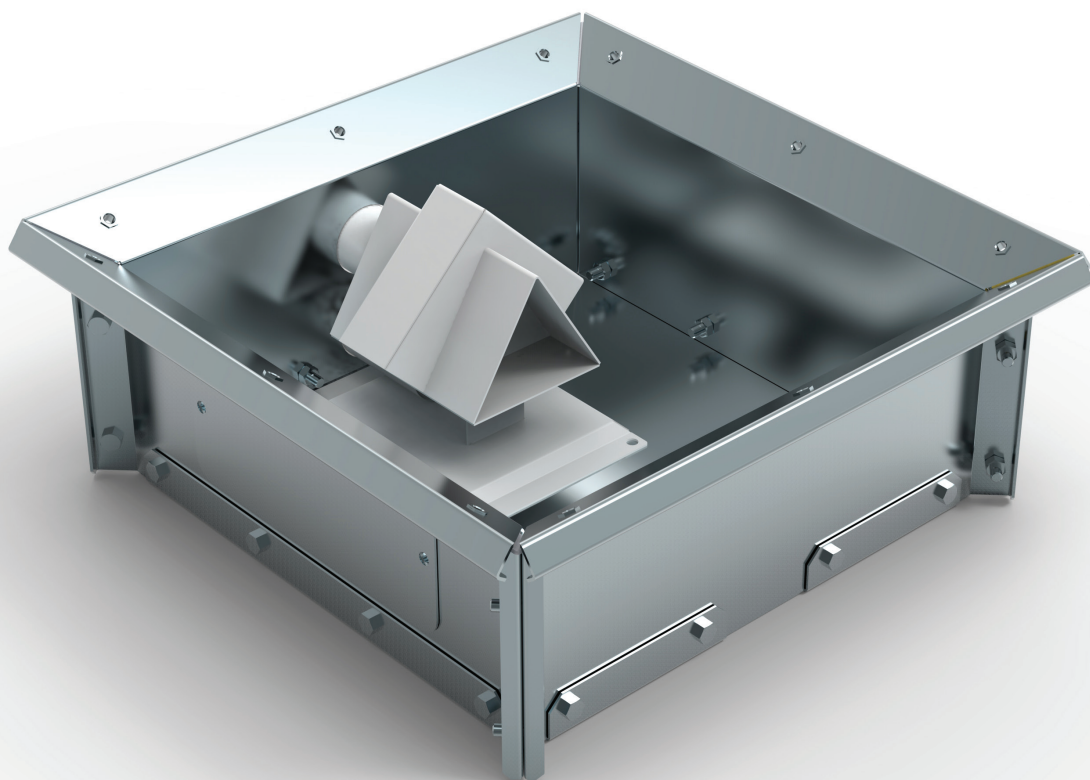







IT - Manuale







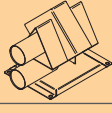







DE: LIEFERUMFANG
 EN: SCOPE OF DELIVERY
 FR: VOLUME DE LIVRAISON
 IT: CONTENUTO DELLA CONSEGNA
 ES: VOLUMEN DE ENTREGA

DE: LIEFERUMFANG (DN45)
 EN: SCOPE OF DELIVERY (DN45)
 FR: VOLUME DE LIVRAISON (DN45)
 IT: CONTENUTO DELLA CONSEGNA (DN45)
 ES: VOLUMEN DE ENTREGA (DN45)

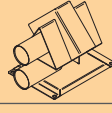
Symbol	Art.Nr.	Stk./pcs.
	(A) 2-100.99.205	2
	(B) 2-100.99.231	1
	(C) 2-100.99.211	1
	(D) 2-100.99.202	1
	(E) 2-100.99.212	1
	(F) M8x20	26
	(G) M8	24
	(H) M6x20 4-900.10.134	2
	(I) M6	2
	(J) 1-100.15.660	1
	(K) 1-100.15.619	4

Symbol	Art.Nr.	Stk./pcs.
	(A) 2-100.99.205	2
	(B) 2-100.99.231	1
	(C) 2-100.99.211	1
	(D) 2-100.99.202	1
	(E) 2-100.99.212	1
	(F) M8x20	26
	(G) M8	24
	(H) M6x20 4-900.10.134	2
	(I) M6	2
	(J) 1-100.15.660	1
	(K) 1-100.15.619	2
	(L) 2-100.60.900	1

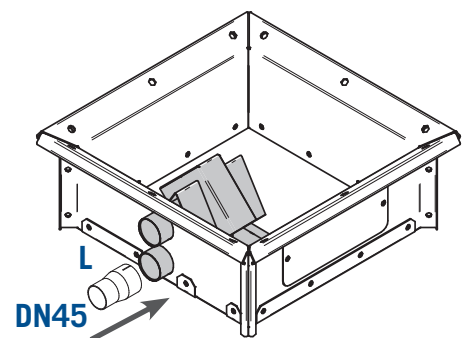
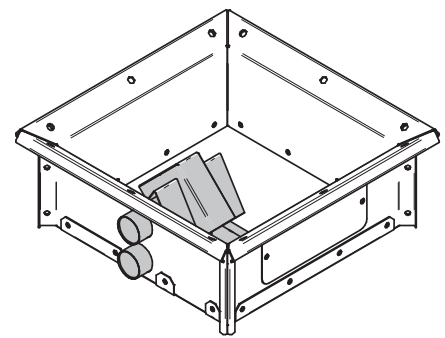
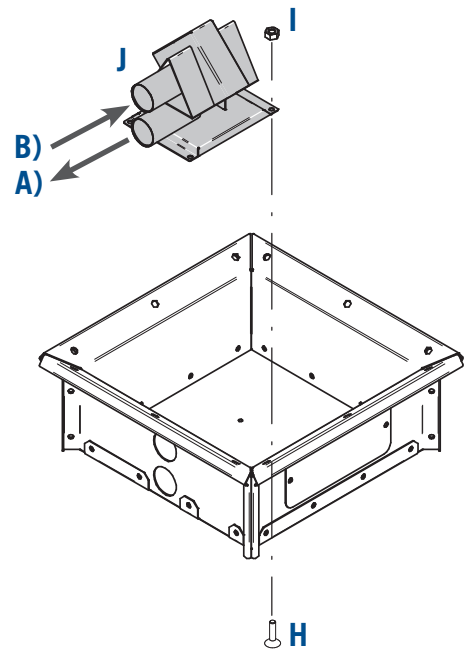
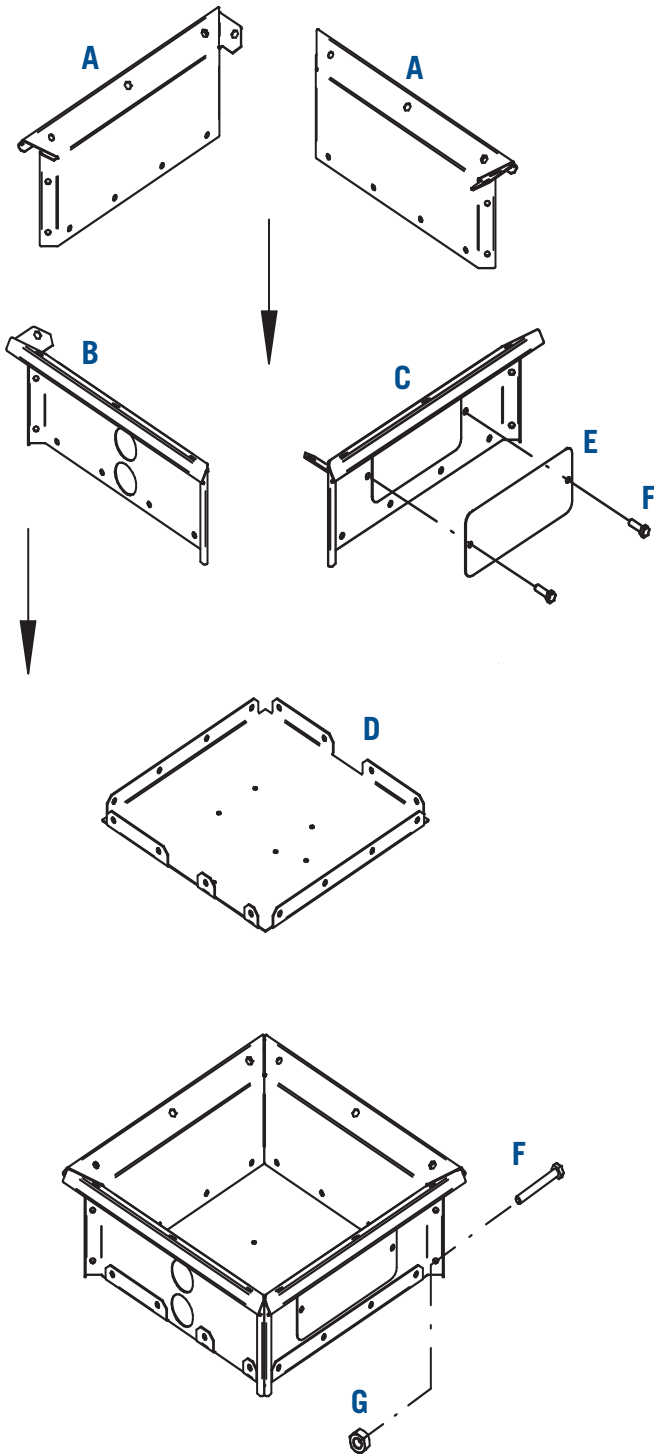

A)

- DE: Anschluss Pelletansaugschlauch.
- EN: Connection pellets suction hose.
- FR: Branchement tuyau d'aspiration de pellets.
- IT: Collegamento tubo d'aspirazione del pellet.
- ES: Conexión manguera de aspiración de pellets.

B)

- DE: Anschluss Rückluftschlauch.
- EN: Connection air return hose.
- FR: Branchement tuyau de retour d'air.
- IT: Collegamento tubo di ritorno aria.
- ES: Conexión manguera de retorno del aire.

